

PA12

Single Point Aluminum Load Cell

TRUE-TEC

Quality by Advanced Technology



FEATURES

- Capacity 50-635kg
- Aluminum Construction
- Single point 600x800 mm platform
- OIML R60/2017 approved to C8 class maximum
- Available with Metric threads
- Excellent Eccentric Loading performance
- IP66 protection

OUTLINE DIMENSIONS

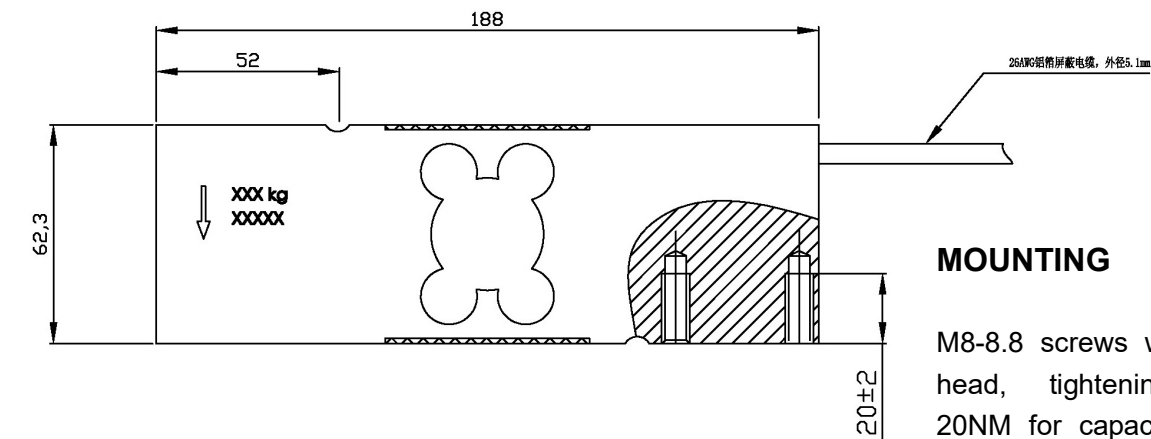

MOUNTING

M8-8.8 screws with socket head, tightening torque 20NM for capacities up to 250kg, and 25NM for capacities above 250kg

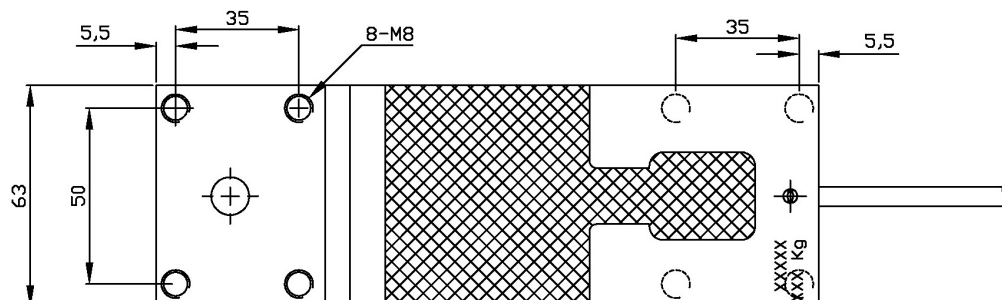

SPECIFICATION

PARAMETER	UNIT	VALUE				
		N	P	R	T	V
True-Tec Grade						
OIML Accuracy Class		C2	C2.5	C3	C4	C6
Rated capacity (E_{max})	kg	50, 100, 150, 200, 250, 300, 500, 635				
Sensitivity	mV/V	2.00				
Sensitivity tolerance	± mV/V	0.20				
Zero balance	± mV/V	0.10				
$Y=E_{max}/v_{min}$	Minimum	3000	5400	10000	10000	12000
$Z=E_{max}/(2*DR)$	Minimum	2000	2500	3000	4000	6000
Temperature effect on output	± %/10 °C	0.014	0.010	0.010	0.0083	0.0083
Eccentric loading error	±%/cm	0.0057	0.0042	0.0042	0.0036	0.0024
Maximum platform size	cm	60x60				
Nominal temperature range	°C	-10 to +40				
Service temperature range	°C	-30 to +70				
Limit load	% of R.C.	150				
Break load	% of R.C.	300				
Nominal excitation	V	10				
Max. excitation	V	15				
Input impedance	Ohm	406 ± 15				
Output impedance	Ohm	350 ± 3				
Insulation resistance	MOhm	>2000				
Compensation circuit type		Balanced Bridge				
Cable length	m	2.0				
Cable type		4x26 AWG, Black PVC Jacket				
Color code		+exc -green, +sig-red, -exc-black, -sig- white				
Construction		Aluminum				
Protection class to IEC529		IP 66				

*-6 wire 26AWG PVC cable available to order

** -Special combination of nmax, Y and Z value available to order

APPLICATIONS

Model PA12 is a high performance, high capacity single point load cell designed for direct mounting of large weigh platforms.

The rugged construction offers high immunity to side forces making it suitable for a wide range of weighing applications, including bench scales, check weighing and process weighing.

A special humidity resistant protective coating assures long term stability over the entire compensated temperature range.

The PA12 provides scale manufacturers with a high accuracy low cost sensor to meet today's needs.

Due to True-Tec's Policy of continuous development, these specifications are subject to change without notice.

All details describe our products in general form only. They are not to be understood as express warranty and do not constitute any liability whatsoever.

Beijing True-Tec Co., Ltd.

4/F, Bldg. 2, No. 8, Hong Da Bei Lu,

BDA, Beijing 100176, China

Tel.: +86-10-67869219 Fax: +86-10-67862581

E-mail: info@true-tec.com

www.true-tec.com